

## Silicon reagents in chemical transformations: the concept of 'counterattack reagent'\*

Jih Ru Hwu,†<sup>a,b</sup> Shwu-Chen Tsay,<sup>a</sup> Ke Yung King<sup>b</sup> and  
Den-Nan Horng<sup>c</sup>

<sup>a</sup>Organosilicon and Synthesis Laboratory, Institute of Chemistry, Academia Sinica, Nankang, Taipei, Taiwan 11529; <sup>b</sup>Department of Chemistry, National Tsing Hua University, Hsinchu, Taiwan 30043; and <sup>c</sup>Department of Physics and Chemistry, Chinese Military Academy, PO Box 90602-6, Feng-shan, Taiwan, Republic of China

**Abstract:** Heteroatom-containing reagents  $\text{Me}_3\text{SiOOSiMe}_3$ ,  $\text{Me}_3\text{SiSiMe}_3$ , and  $(\text{Me}_3\text{Si})_3\text{N}$  are utilized for the performance of efficient chemical transformations in 'one-flask.' Oxidative desulfonylation of organic sulfones to the corresponding carbonyl compounds by use of  $\text{Me}_3\text{SiOOSiMe}_3$  and *n*-BuLi involves a simple 'counterattack process'. Double functional group transformation of a nitroalkene to a carbonyl nitrile with  $\text{Me}_3\text{SiSiMe}_3$  went through a 'tandem double-counterattack process'. Persilylation of hydrazine with  $\text{Me}_3\text{SiSiMe}_3$  in the presence of KH took place by a 'consecutive triple-counterattack process'. Polymerization of trimethyl phosphate with  $(\text{Me}_3\text{Si})_3\text{N}$  in the presence of *n*-BuLi represents an extreme example: 'multiple-counterattack process'. Use of  $\text{Me}_3\text{SiOOSiMe}_3$ ,  $\text{Me}_3\text{SiSiMe}_3$ , and  $(\text{Me}_3\text{Si})_3\text{N}$  as 'counterattack reagents' allows the accomplishment of complicated chemical transformations with minimal operations and often gives the desired products in good yields.

### INTRODUCTION

The study of reactions involving heteroatoms and their mechanisms has become a research field of great activity. The outcomes can be widely applied to organic synthesis. Our research group has been devoting efforts to silicon chemistry related to new reactions, mechanistic studies, reagent design, and efficient synthetic methods. One of our goals is to obtain results that are of value for the invention of new materials.

Herein we wish to report efficient ways to use reagents containing an Si–O, Si–N or Si–Si bond in chemical transformations. The strategy involves the concept of 'counterattack reagent' [1,2]. The design and significance of our approaches will be illustrated in the representative examples including: (i) conversion of sulfones to carbonyl compounds with  $\text{Me}_3\text{SiOOSiMe}_3$ ; (ii) a double functional group transformation of a cyclonitroalkene to a carbonyl nitrile with  $\text{Me}_3\text{SiSiMe}_3$ ; (iii) persilylation of hydrazines to tetrasilylhydrazines with  $\text{Me}_3\text{SiSiMe}_3$ ; and (iv) synthesis of silicon-containing polyphosphazenes involving  $(\text{Me}_3\text{Si})_3\text{N}$ .

### Simple counterattack process: $\text{Me}_3\text{SiOOSiMe}_3$ in the conversion of sulfones to aldehydes or ketones

The first heteroatom-containing reagent to be discussed is a peroxide,  $\text{Me}_3\text{SiOOSiMe}_3$ . It contains a very weak O–O bond and a common Si–O bond. This peroxide can be used efficiently in an oxidative desulfonylation of sulfones to aldehydes or ketones under basic conditions, as shown in Scheme 1 [3].

\*Lecture presented at the 5th International Conference on Heteroatom Chemistry (ICHAC-5), London, Ontario, Canada, 5–10 July 1998, pp. 369–512.

†Corresponding author.

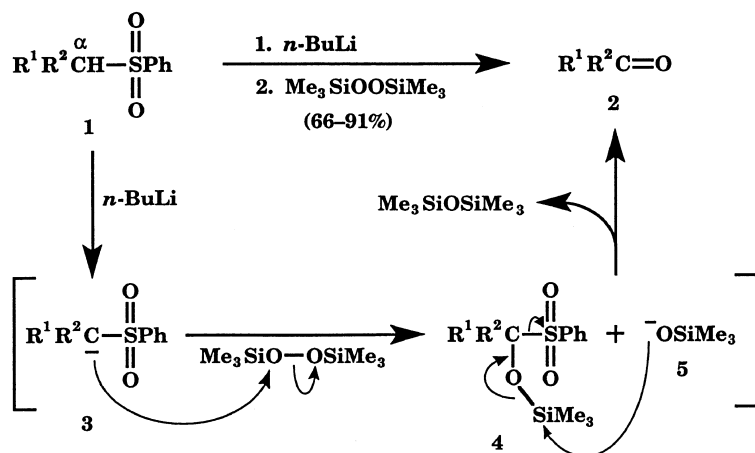

$\text{R}^1 = \text{H, Et, R}^2 = \text{CH}_3(\text{CH}_2)_4, \text{Ph}$

$\text{R}^1 + \text{R}^2 = -(\text{CH}_2)_3\text{CH}=\text{CH}-, -(\text{CH}_2)_5-, -(\text{CH}_2)_4-$

Scheme 1

Removal of an  $\alpha$  proton in sulfones **1** with *n*-BuLi gives carbanions **3**. The reagent  $\text{Me}_3\text{SiOOSiMe}_3$  is then attacked by **3** to afford siloxysulfones **4** and nucleofuge  $\text{Me}_3\text{SiO}^-$  (**5**). Subsequently, the siloxysulfones **4** are counterattacked by  $\text{Me}_3\text{SiO}^-$  *in situ* to produce the desired carbonyl products **2**. Thus  $\text{Me}_3\text{SiOOSiMe}_3$  acts as a 'counterattack reagent' in this oxidative desulfonylation. This 'one-flask' method can be used to convert alkyl, allylic, benzylic, and cycloalkyl sulfones to aldehydes or ketones in 66–91% yields.

### Tandem double-counterattack process: $\text{Me}_3\text{SiSiMe}_3$ in the conversion of a nitroalkene to a carbonyl nitrile

Design of a double functional group transformation often encounters high complexity. Once the transformation is established, the results could be beneficial to organic synthesis. One highly regarded example is Eschenmoser's transformation of  $\alpha,\beta$ -epoxy ketones to carbonyl acetylenes as shown in Scheme 2 [4]. Such a conversion can be exceedingly useful because it minimizes the need for manipulation of synthetic intermediates. We planned to develop a new synthetic strategy to convert nitroalkenes to carbonyl nitriles (e.g. see Scheme 2). On the basis of the mechanistic complexity and synthetic applicability, this new transformation may be comparable with Eschenmoser's process.

A traditional way to complete the transformation of **6**  $\rightarrow$  **7** involves the use of potassium methoxide

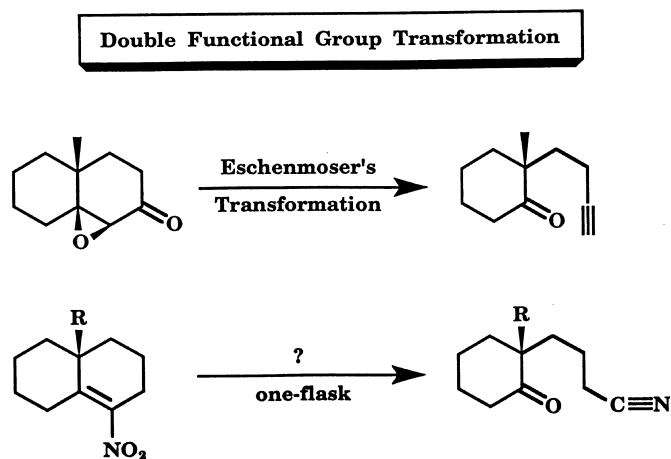

Scheme 2

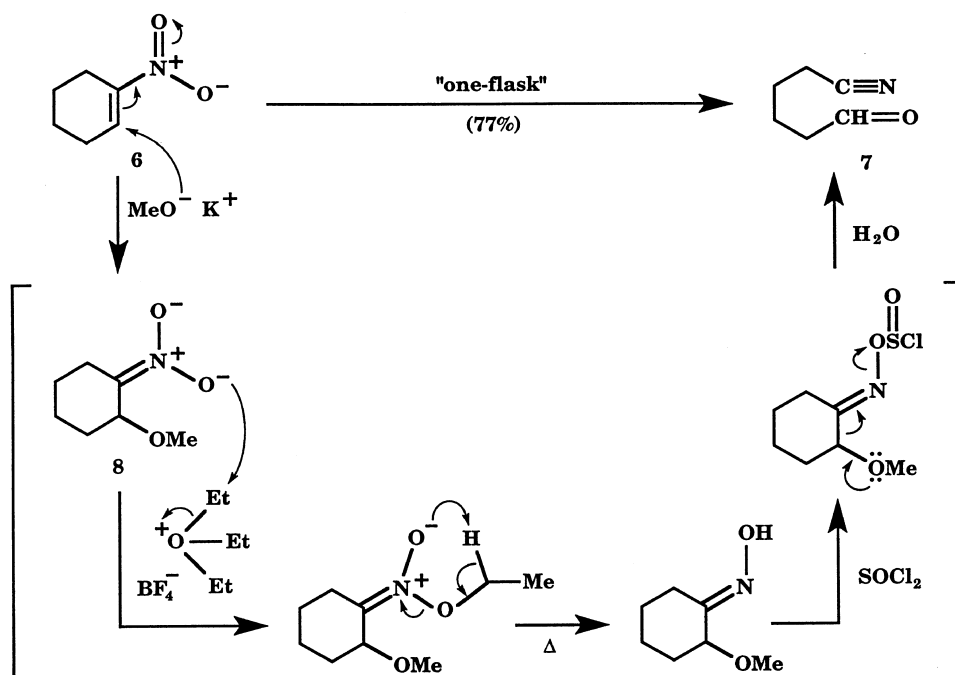

Scheme 3

(1.5 equiv), triethyloxonium tetrafluoroborate (1.5 equiv), and thionyl chloride (2.0 equiv) in sequence in 1,2-dimethoxyethane [5]. The desired product **7** is generated in 77% yield. The mechanism in detail is illustrated in Scheme 3.

To avoid utilization of the strong alkylating agent triethyloxonium tetrafluoroborate, we developed an alternative method involving the heteroatom-containing agent  $\text{Me}_3\text{SiSiMe}_3$ . This reagent contains a relative weak Si–Si bond (80.5 kcal/mol; [6]). We performed the 1,4-addition of  $\text{KOMe}$  to **6** under aprotic conditions to give nitronate **8** as shown in Scheme 4 [7]. Heteroatom-containing  $\text{Me}_3\text{SiSiMe}_3$  reagent is then added into the reaction media and is attacked by **8** to give trimethylsilyl nitronate **9**. The  $\text{Me}_3\text{Si}^-$  liberated *in situ* then counterattacks at the electrophilic  $\text{C}=\text{N}^+$  carbon in **9** to afford unstable  $\alpha$ -trimethylsilyl-*N*-oxide **10**. Decomposition of **10** through a 1,2-elimination [8] affords silylated oxime **11** and  $\text{Me}_3\text{SiO}^-$ . The  $\text{Me}_3\text{SiO}^-$  species performs the second counterattack on **11**. Upon treatment with acid, the resultant oxime anion forms unstable intermediate **12**, which undergoes a Beckmann fragmentation to give the desired carbonyl nitrile **7** in 52% yield along with  $\text{Me}_3\text{SiOSiMe}_3$  as a by-product.

The entire process shown in Scheme 4 involves one attack step (i.e. **8**  $\rightarrow$  **9**) and two counterattack steps (i.e. **9**  $\rightarrow$  **10** and **11**  $\rightarrow$  **12**). Both of the counterattacking species  $\text{Me}_3\text{Si}^-$  and  $\text{Me}_3\text{SiO}^-$  originate from the same reagent  $\text{Me}_3\text{SiSiMe}_3$ . Such a process can be classified as a ‘tandem double-counterattack process’.

### Consecutive triple-counterattack process: $\text{Me}_3\text{SiSiMe}_3$ in the persilylation of hydrazines to tetrasilylhydrazines

A typical way to prepare  $(\text{Me}_3\text{Si})_2\text{NN}(\text{SiMe}_3)_2$  (**14**) from  $\text{H}_2\text{NNH}_2$  (**13**) includes three separate silylations, two different bases (i.e. pyridine and *n*-BuLi), and two strong silylating agents (i.e.  $\text{Me}_3\text{SiCl}$  and  $\text{Me}_3\text{SiBr}$ ). The overall yield is only  $\approx 8\%$  [9]. We applied the strategy of ‘counterattack reagent’ to solve this problem. It involves the use of heteroatom-containing reagent  $\text{Me}_3\text{SiSiMe}_3$  (Scheme 5). Treatment of  $\text{H}_2\text{NNH}_2$  with KH (0.30 equiv) and  $\text{Me}_3\text{SiSiMe}_3$  (4.2 equiv) in THF and HMPA at room temperature for 72 h gives the desired tetrasilylated hydrazine **14** in 91% yield [10].

As shown in Scheme 5, we illustrate this ‘one-flask’ preparation of tetrakis(trimethylsilyl)hydrazine (**14**) from hydrazine (**13**) and  $\text{Me}_3\text{SiSiMe}_3$  under alkaline conditions. The disilane,  $\text{Me}_3\text{SiSiMe}_3$ , plays a dual role in this reaction: silylating agent and source of base. In the overall process, proton abstraction alternates with silylation. This alternation is repeated four times; yet three molecules of  $\text{Me}_3\text{SiSiMe}_3$

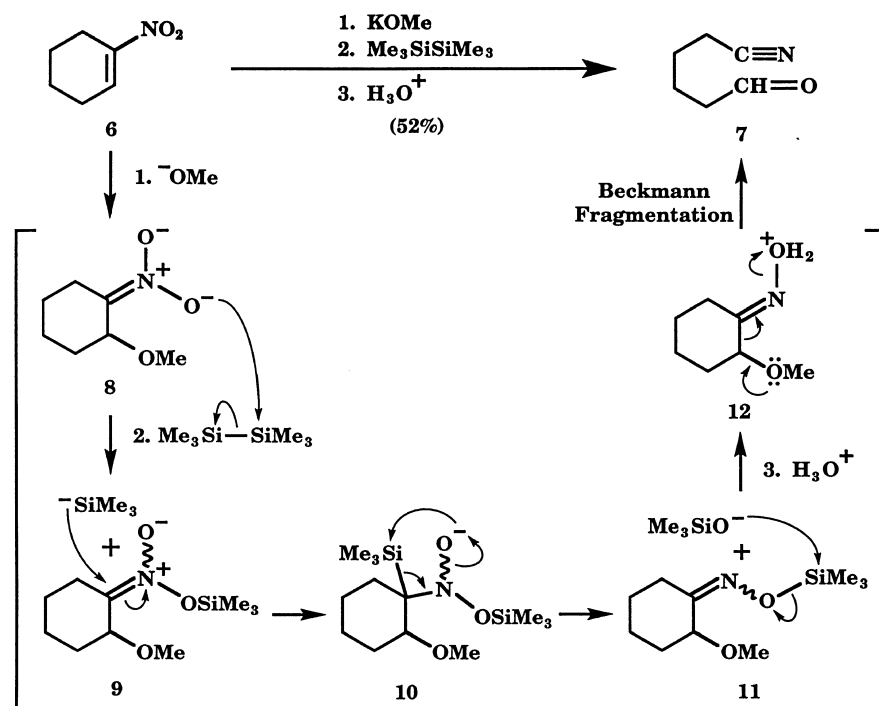

Scheme 4

participate in the attack and counterattack steps. Accordingly, it represents an example of ‘consecutive triple-counterattack process.’ Use of the same synthetic strategy allows us to obtain many di- and trisilylated hydrazines in 65–99% yields.

### Consecutive multiple-counterattack process: (Me<sub>3</sub>Si)<sub>3</sub>N in the conversion of trimethyl phosphate to silicon-containing polyphosphazenes

Polyphosphazenes (**15**) possessing a –P=N– backbone chain are some of the most intensively studied macromolecules [11–13]. The properties of polyphosphazenes depend upon the substituents R<sup>1</sup> and R<sup>2</sup>. With various structural modifications, these polymers can be used as new materials with industrial and

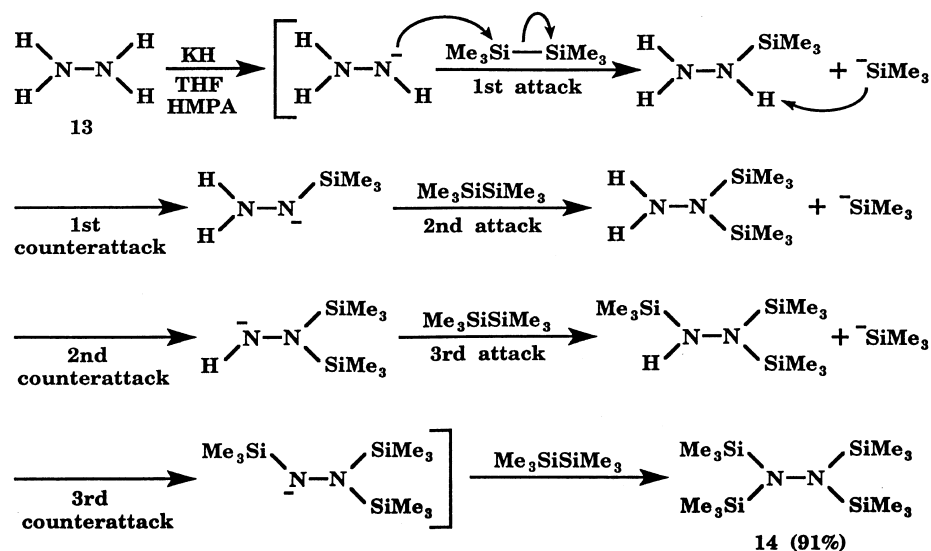

Scheme 5

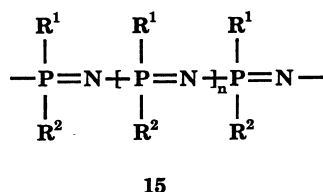

Scheme 6

biomedical values. Several general methods [11,12,14,15] can be used for the construction of the polyphosphazene backbone (Scheme 6).

We developed a new and efficient synthetic method for synthesis of silicon-containing polyphosphazenes based on the 'counterattack reagent' concept. Reaction of trimethyl phosphate (16) with a stoichiometric amount of  $(\text{Me}_3\text{Si})_3\text{N}$  (17) and a catalytic amount of *n*-BuLi (2–10 mol%) in THF at room temperature for six days gave silicon-containing polyphosphazenes 18 as a white solid in 60% yield (Scheme 7). Their  $^1\text{H}$  NMR spectrum showed two peaks at 0.18 and 3.55 p.p.m. for  $\text{Si}(\text{CH}_3)_3$  and  $\text{OCH}_3$ , respectively. The infrared spectrum indicates a strong absorption at  $1245\text{ cm}^{-1}$  for the  $\text{P}=\text{N}$  stretching vibration, which is characteristic for polyphosphazene polymers [16], and at  $1050\text{ cm}^{-1}$  for the  $\text{Si}-\text{O}$  bond.

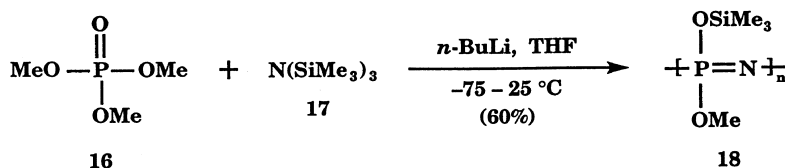

Scheme 7

The mechanism shown in Scheme 8 presents our design of the 'one-flask' polymerization. It is initiated by a catalytic amount of *n*-BuLi, which reacts with  $(\text{Me}_3\text{Si})_3\text{N}$  (17). Carbanion *n*-Bu<sup>-</sup> nucleophilically attacks a silicon atom in 17 to give  $^-\text{N}(\text{SiMe}_3)_2$ . Nucleophile  $^-\text{N}(\text{SiMe}_3)_2$  then reacts with  $(\text{MeO})_3\text{P}=\text{O}$  (16) to give oxide 19. Oxide 19 decomposes to amidophosphate 20 and  $^-\text{OMe}$ . Nucleophilic attack of 20 at a silicon center with  $^-\text{OMe}$  gives anion 21 and  $\text{MeOSiMe}_3$ . Subsequently, a 1,3-intramolecular migration of the  $\text{Me}_3\text{Si}$  group occurs in 21 to give phosphonimide anion 22.

Phosphonimide anion 22 could also be generated from oxide 19 by an alternative pathway (Scheme 8,  $19 \rightarrow 23 \rightarrow 24 \rightarrow 22$ ). Instead of decomposing to 20, oxide 19 may be led to amide 23 by a  $\text{Me}_3\text{Si}$  migration. Fragmentation of 23 to phosphonimide 24 and  $^-\text{OMe}$ , followed by an intermolecular  $\text{Me}_3\text{Si}$  transfer between 24 and  $^-\text{OMe}$ , can also give phosphonimide 22.

Phosphonimide 22 reacts with the second molecule of  $(\text{MeO})_3\text{P}=\text{O}$  (16) to form the dimer 27 and  $^-\text{OMe}$ . Species  $^-\text{OMe}$ , having the same function as the base *n*-BuLi, then nucleophilically attacks  $(\text{Me}_3\text{Si})_3\text{N}$  (17) to give  $^-\text{N}(\text{SiMe}_3)_2$ . Addition of  $^-\text{N}(\text{SiMe}_3)_2$  to 27 affords the amidophosphate 28.

The dimer 27 could also be generated from amide 21 by a different pathway  $21 \rightarrow 25 \rightarrow 26 \rightarrow 27$ . Reaction of 21 with the second molecule of  $(\text{MeO})_3\text{P}=\text{O}$  (16) produces *N*-silylated amidophosphate 25 and  $^-\text{OMe}$ . Amidophosphate 25 is then attacked by  $^-\text{OMe}$  at the silicon center to give oxide 26. Silylation of oxide 26 with the second molecule of  $(\text{Me}_3\text{Si})_3\text{N}$  (17) can also produce the dimer 27 and  $^-\text{N}(\text{SiMe}_3)_2$ .

Conversion of 28 to 29 with  $(\text{MeO})_3\text{P}=\text{O}$  (16) follows the same mechanism for the conversion of 19 to 27. After numerous repetitions of the same process, the silicon-containing polyphosphazenes  $-\text{[N}=\text{P}(\text{OSiMe}_3)(\text{OMe})]_n-$  (18) are obtained. In this polymerization,  $(\text{Me}_3\text{Si})_3\text{N}$  (17) acts as a 'counterattack reagent.' Because many individual molecules of 17 are involved in the attack and the counterattack steps, the transformation shown in Scheme 8 represents an example of 'consecutive multiple-counterattack process.'

Our strategy for the synthesis of polyphosphazenes 18 involves only one reaction. From the mechanistic viewpoint, this reaction includes several transformations *in situ*. The design is on the basis of

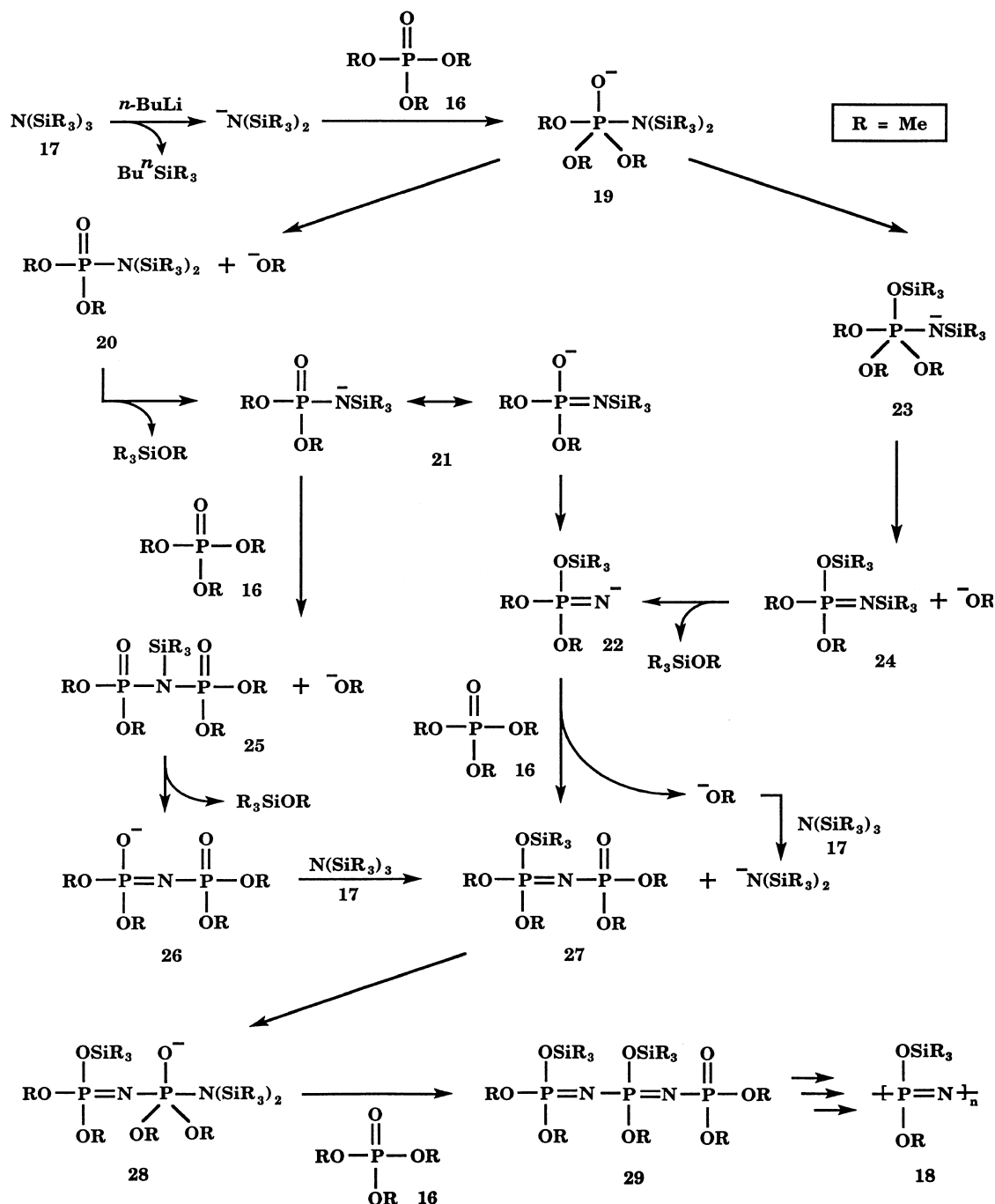

Scheme 8

an intriguing way to use the heteroatom-containing reagent  $(\text{Me}_3\text{Si})_3\text{N}$ : both the electrophilic and the nucleophilic moieties in  $\text{N}(\text{SiMe}_3)_3$  play important roles in the polymerization.

## CONCLUSIONS

Four representative examples have been discussed for illustration of our efficient ways to use heteroatom-containing reagents in organic synthesis and polymerization. These reagents,  $\text{Me}_3\text{SiOOSiMe}_3$ ,  $\text{Me}_3\text{SiSiMe}_3$  and  $(\text{Me}_3\text{Si})_3\text{N}$ , function as 'counterattack reagents.' The transformations may go through a simple, double-, triple-, or multiple-counterattack process.

By use of the concept of 'counterattack reagent', a multistep chemical transformation could be simplified into a 'one-flask' reaction. In comparison with established, classic methods, this type of new approach often gives higher yields for the products with less manipulation.

## ACKNOWLEDGEMENTS

For financial support, we thank the National Science Council of Republic of China and Academia Sinica.

## REFERENCES

- 1 J. R. Hwu, S.-C. Tsay. *J. Chem. Soc., Chem. Commun.* 161 (1998).
- 2 J. R. Hwu, B. A. Gilbert. *Tetrahedron* **45**, 1233 (1989).
- 3 J. R. Hwu. *J. Org. Chem.* **48**, 4432 (1983).
- 4 A. Eschenmoser, D. Felix, G. Ohloff. *Helv. Chim. Acta* **50**, 708 (1967).
- 5 J. R. Hwu, N. Wang. *J. Chem. Soc., Chem. Commun.* 427 (1987).
- 6 R. Walsh. *Acc. Chem. Res.* **14**, 246 (1981), and references cited therein.
- 7 J. R. Hwu, N. Wang. *Synth. Commun.* **18**, 21 (1988).
- 8 J. R. Hwu, J. M. Wetzel. *J. Org. Chem.* **50**, 400 (1985).
- 9 K. Seppelt, W. Sundermeyer. *Chem. Ber.* **102**, 1247 (1969).
- 10 J. R. Hwu, N. Wang. *Tetrahedron* **44**, 4181 (1988).
- 11 H. R. Allcock. *Polym. Mater. Sci. Eng.* **76**, 49 (1997), and references cited therein.
- 12 H. R. Allcock, S. E. Kuharcik. *J. Inorg. Organomet. Polym.* **6**, 1 (1996), and references cited therein.
- 13 C. W. J. Grolleman, A. C. deVisser, J. G. C. Wolke, H. van der, Goot, H. Timmerman. *J. Controlled Release* **3**, 143 (1986).
- 14 (a) R. H. Neilson, R. Hani, G. M. Scheide, U. G. Wettermark, P. Wisian-Neilson, R. R. Ford, A. K. Roy. In *Inorganic and Organometallic Polymers* (M. Zeldin, K. J. Wynne, H. R. Allcock, eds) ACS Symposium Series 360, Chapter 22. American Chemical Society, Washington, DC (1988). (b) R. A. Montague, K. Matyjaszewski. *J. Am. Chem. Soc.* **112**, 6721 (1990).
- 15 For the synthesis of a silylalkylated polyphosphazene by anionic polymerization, see: H. R. Allcock, D. J. Brennan, B. S. Dunn. *Macromolecules* **22**, 1534 (1989).
- 16 H. R. Allcock, R. L. Kugel, K. J. Valan. *Inorg. Chem.* **5**, 1709 (1966).